

Mx350i-DW

Compact, airless and cost-effective labeling

The smallest labeling solution in the **Mx-Series** range, the **Mx350i-DW** offers a direct-wipe system for simple labeling requirements. It provides fast and accurate labeling on moving products or packages without requiring any compressed air. It is a cost-efficient model, yet it maintains the same overall clean design and flexibility that the Domino print and apply range is well known for.



Easy to integrate

- ◆ Advanced connectivity options enable effortless integration with ERP, WMS, and MES systems within your factory, for smooth operation and enhanced productivity.
- ◆ With one of the most flexible and streamlined designs on the market, the **Mx350i-DW** print and apply solution is available in both left- and right-hand variants, for seamless integration into any production line.

Easy to use

- ◆ The **Mx350i-DW** is made user-friendly with its integrated UI and optional remote 10-inch touchscreen, ensuring easy operation.
- ◆ The robust design and clever functionality minimize the time required for media changes and maintenance, so you can maximize production uptime.

Easy to adapt

- ◆ The **Mx350i-DW** is built to endure, promising a long life, while its adaptability ensures it can meet your evolving labeling needs without requiring costly investments.
- ◆ The system is highly configurable and offers a multitude of options to further refine and simplify your labeling processes.



www.domino-printing.com



A complete solution for all labeling needs



Our services are designed to provide operational insight so you can reduce downtime and maximize production efficiency

Operational support

Our extended warranty packages provide high-quality, on-site assistance and augmented reality-enabled remote guidance from our engineers. **SafeGuard** helps to ensure we can be with you when you need us most.

Automatic code inspection

Ensure every code that leaves your factory is present and correct, and free up operator time. With **R-Series**, Domino's range of vision control systems, you can automate your code inspection to validate code presence, placement, and readability.

Central label management

Domino Automation easily integrates into your manufacturing process as well as your ERP/MES systems. It makes automatic changeovers safe and simple, helping you to reduce waste and drive sustainability initiatives while increasing productivity and efficiency.

Smart production

Gain operational insight by connecting your printer to **Domino Cloud**. Obtain production analytics dashboards and receive system error alerts. **Domino Cloud** provides you with the information you need to run your operations more efficiently.



Technical specification Mx350i-DW

Model	Mx350i-DW4	Mx350i-DW6
Print width	108mm (4-inch)	162mm (6-inch)
Print technology	Thermal transfer / Direct thermal	
Print resolution	12 dots/mm (300dpi)	
Printer variants	Left hand or Right hand	
Max print speed	400mm/s	250mm/s
Distance to product	0mm	
Product motion	Moving	
Apply method	Direct wipe	
Label position		
Recommended label width	25-110mm (1-4")	25-166mm (1-6")
Recommended label length	30-300mm (1.2-11.8")	
Label & ribbon roll length	Up to 600m	
Input voltage	90-250VAC 50/60Hz	
Communication	4x Ethernet, TCP/IP, 2x USB-A, 1x USB-B	
I/Os (configurable)	12 inputs and 12 outputs	

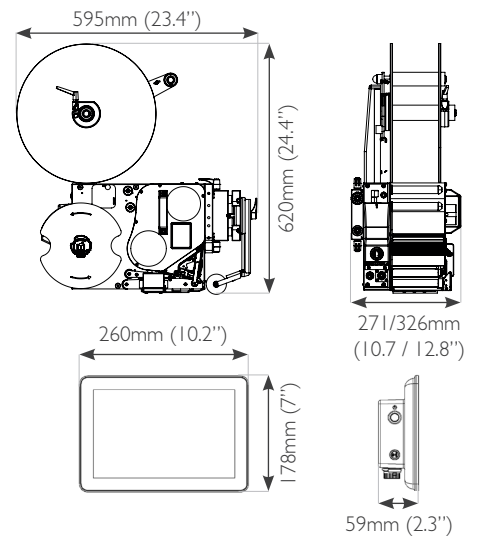

CONTACT US

TALK TO AN EXPERT

- 800.444.4512
- solutions@domino-na.com
- www.domino-na.com/contact