



Domino UK Projects Department

Domino's keg labeller has been optimised for maximum productivity

Print & Apply Keg Labelling – Application Profile

This Solution has been developed by Domino UK specifically for the Beverage Industry. It serves as a replacement for the current process of manually applying labels to the top of Beer Kegs. Traceability of the product is key from the brewery to the public house and the return of the keg/cask.

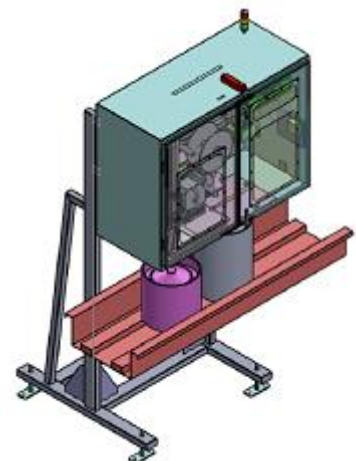
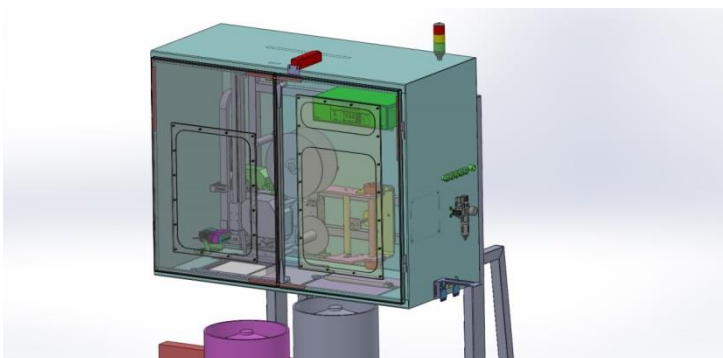

High quality
printed labels with
full supply chain
compliance applied
automatically to
your keg or cask

This system was designed by our team of Project Engineers to automate the manual process of keg/cask Labelling. The label includes a barcode for traceability but also provides the landlords with mandatory product description and best before date.

Specification:

- **Stainless steel cabinet with a timed sliding door in the base for protection.**
- **The labeller is mounted on a pivot mechanism which allows the printer to be pulled out 90 degrees to the cabinet, allowing easy access for maintenance.**
- **A heater and positive air system can be positioned in the cabinet to maintain its integrity.**
- **Both Thermal and Direct Thermal options available with a 300dpi print resolution.**
- **Auto Ranging Tamp/Blow Cylinder Stroke, with various cylinder lengths available.**
- **QuickDesign software for networking or stand-alone use with Optional Touch Panel.**
- **Bar Code reader is mounted to the side panel to verify the printed Bar Codes.**
- **Versatile range of applicators.**

If you would like to discuss potential applications for Keg Labelling on your production line, please contact:

Domino UK Ltd
Trafalgar Way, Bar Hill
Cambridge CB3 8TU
Tel: 01954 782 551
Fax: 01223 771662
Email: enquiries@domino-uk.com

